

Veljan Flanged type, Valves Series VR5V (Relief), VR5U (Unloader) and VR5S (Sequence) are pilot controls. These range of valves are suitable for mounting directly on a SAE Pump outlet flange, ensuring maximum pump protection against peak pressure and eliminating costly piping. The pilot stage of VR5 valves are designed to reduce pressure overshoot and minimise cracking flow, thus reducing power and production losses during high pressure operation.

VR5 valves consist of a high flow poppet type seat valve section controlled by the low flow, adjustable pilot section mounted on top.

Pressure setting is achieved by means of a knurled knob. For tamper proof setting, acorn nut with lead seal is available as option. Optional Vent Valve VV01 sandwiched between pilot section and main body can be used for venting the VR5 valves.

Exceptionally fast response is obtained due to precise ratio between main piston area and its mass. High accuracy and quiet, flutter free control are the important characteristics of VR5 valves.

### Pressure Relief valve VR5V

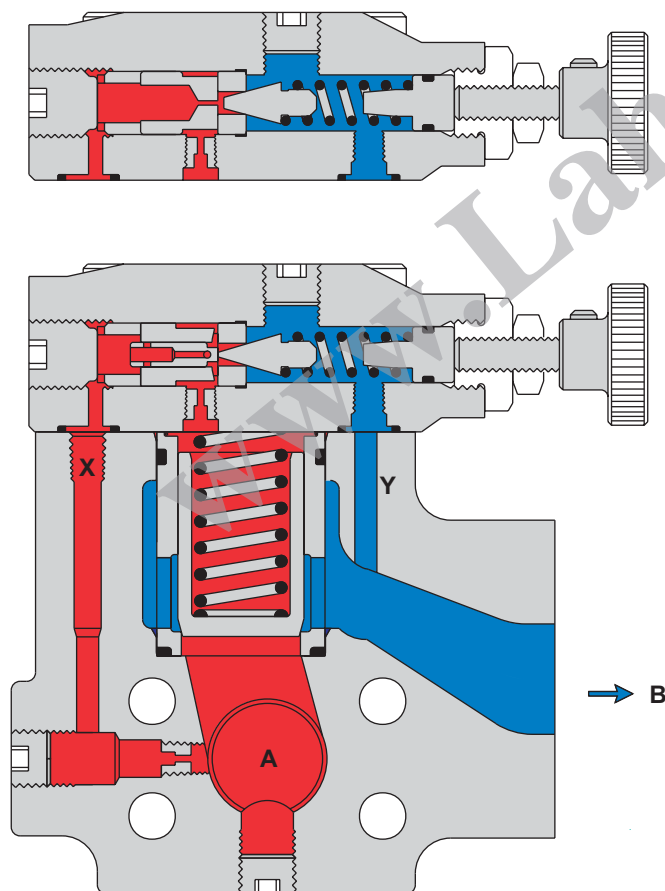

Internal Drain

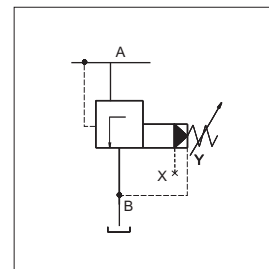

External Drain

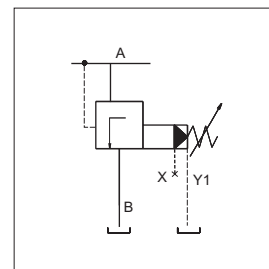

VR5V Pressure relief valves are used to limit the pressure of a hydraulic system. The VR5V may also be used to generate a pressure drop in a hydraulic circuit. Normally port A is connected to pump and port B to tank.

PC

## Pressure unloading valve VR5U

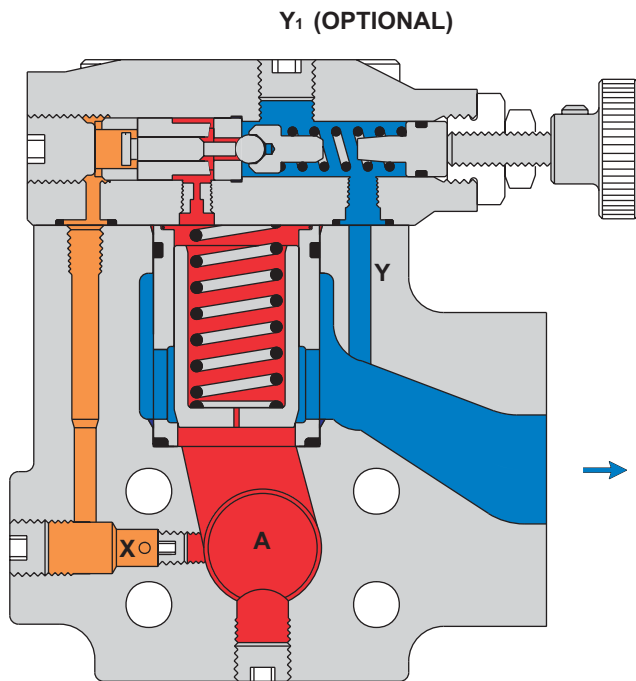

Internal Drain

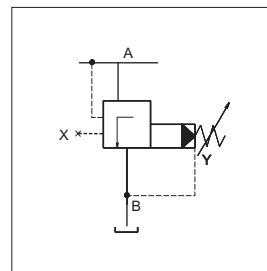

External Drain

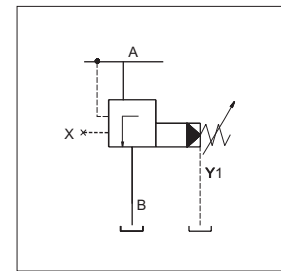

Accumulator system with unloading valve VR5U

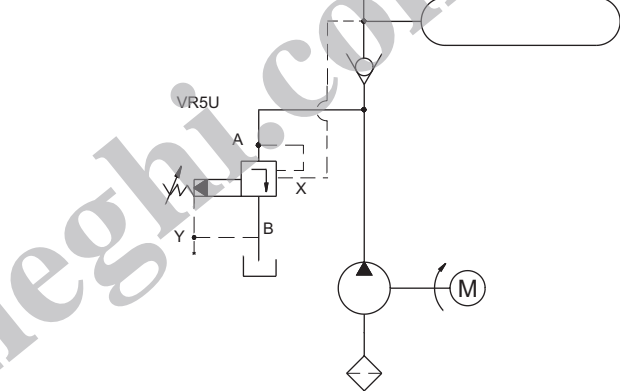

VR5U pressure unloading valves are used to unload a circuit at low pressure when a port signal ( X ) is maintained at a pressure that is higher than that of the pilot section. A typical application for VR5U is to unload a pump that is connected to an accumulator circuit. Another use for the VR5U is to unload the low pressure side of a double pump.

## Pressure sequence valve VR5S

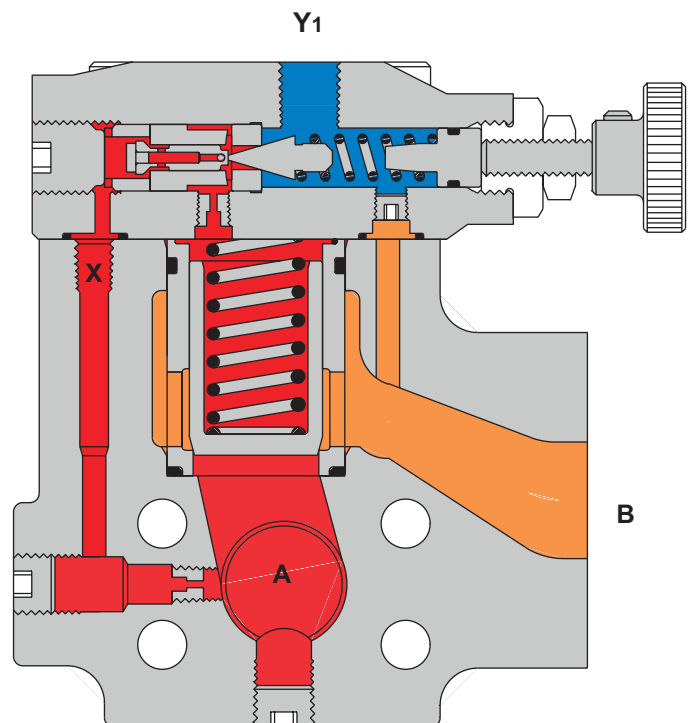
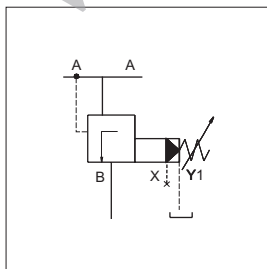

VR5S valve enables a hydraulic system to operate in a pressure sequence. After system pressure connected to port A has reached a preadjusted value, fluid is allowed to pass through port B to a secondary system.

## SPECIFICATIONS

### General

Type	:	Pilot operated Relief/Unloading/Sequence Valve
Design	:	Poppet type
Mounting	:	Flanged According to SAE - 3000 psi (210 bar) e.g. Directly on a pump VR5V12 also 6000 psi (420 bar)
Mounting position	:	Optional
Port sizes (nominal)	:	3/4", 1", 1 1/4" 1 1/2" ( only for VR5V and VR5U)
Direction of flow	:	A→B
Ambient temperature	:	-20°C...+ 60°C (-4°F...+140°F)
Special working conditions	:	Consult <b>VELJAN</b>

### Hydraulics

Pressure control range	:	Minimum - depends on flow Maximum - 5000 psi (350 bar) For VR5V12 - 6000 psi (420 bar)
Maximum operating pressure	:	
Port A (inlet)	:	5000 psi (350 bar), For VR5V12 - 6000 psi (420 bar)
Port B (outlet)	:	For VR5V and VR5U - 450 psi (30 bar) For VR5S - 5000 psi (350 bar), must be less than port A
Port X (pilot)	:	5000 psi (350 bar), For VR5V12 - 6000 psi (420 bar)
Port Y, Y1 (Pilot drain )	:	450 psi (30 bar)
Maximum flow gpm (lpm)	:	VR5*06 (3/4") 24 (90) VR5*08 (1") 80 (300) VR5*10 (1 1/4") 159 (600) VR5V/VR5U12 (1 1/2") 159 (600)
Nominal flow gpm (lpm)	:	depends on pump delivery
Fluid	:	Mineral oil as per DIN 51524/25 or other fluids on request
Fluid Temperature Range	:	- 18°C...+ 80°C (0°F...+ 176°F)
Viscosity Range	:	10 to 650 cSt (60 to 3900 SSU)
Optimum operating viscosity	:	30 cSt (180 SSU)
Seal compatibility	:	Code 1 (Buna N) or Code 5 (Viton) (contact Veljan with specific oil details)
Cleanliness recommended	:	Better than NAS 1638 Class 8 or ISO 17/14

### Adjustment

Manual	:	Handwheel
Rotation	:	3.75 rev.
Operating torque	:	0.72 Nm
Electricals ( Vent Valve VVV01)	:	Solenoid
Nominal voltage	:	Refer to Ordering Code
Permissible voltage fluctuation	:	+5%...-10%
Max. coil temperature	:	+155° C (311°F)
Type of current	:	Alternating Current (AC)/Direct Current (DC)
Input power	:	31 W
Holding	:	78 VA
Inrush	:	264 VA
Relative operating period	:	100%
Type of protection	:	I P 65

## ORDERING CODE

**VR5\* 06 - 5 3 5 - 1 4 - 09 - W07 - A 1 \*\*\***

**Series**

VR5V - Pressure Relief Valve  
 VR5U - Pressure Unloading Valve  
 VR5S - Pressure Sequence Valve

**Size**

06 - 3/4"  
 08 - 1"  
 10 - 1 1/4"  
 12 - 1 1/2"

**Max. Pressure of Valve Body**

3 - 3000psi (210 bar) - SAE 61 flange (VR5V12/VR5U12)  
 4 - 4000psi (280 bar) - SAE 61 flange (VR5\* 10)  
 5 - 5000psi (350 bar) - SAE 61 flange (VR5\*06/08)  
 6 - 6000psi (420 bar) - SAE 62 flange (VR5V12 only)

**Body**

Ports X1, Y1<sup>1)</sup>, M  
 1 - 1/4" NPTF  
 3 - SAE - 4 (7/16" - 20 UNF)  
 9 - G 1/4"

<sup>1)</sup> Port Y1 is only available at external drain from the pilot head

**Pressure setting range**

1 - 100 - 1500 psi (7 - 105 bar) } VR5U:Pressure  
 3 - 100 - 3000 psi (7 - 210 bar) } Differential 20%  
 5 - 100 - 5000 psi (7 - 350 bar), VR5U:Pressure Differential 15%  
 6 - 100 - 6000 psi (7 - 420 bar) (VR5V12 only)

**Type of Control**

1 - Hand knob (32mm dia)  
 2 - Hand knob (50mm dia) (not for version with vent valve VV01)  
 3 - Acorn nut with lead seal

**Modification**

**Seal Class**

1 - Buna N ( Standard)  
 5 - Viton

**Design letter**

**Solenoid Voltage**  
 (Omit for non vent version)

W01 - 115V/60 Hz AC GOR - 12V DC  
 W02 - 230V/60 Hz AC GOQ - 24V DC  
 W06 - 115V/50 Hz AC GOH - 48V DC  
 W07 - 230V/50 Hz AC

**Electrical Vent**  
 (3way VENT VALVE VV01)  
 Omit for non vent version

09 - With manual override (Solenoid de-energized : open to tank. Solenoid Energized : vent line blocked)  
 10 - Without manual override (Solenoid de-energized : open to tank. Solenoid energized : vent line blocked)  
 11 - With manual override (Solenoid de-energized : vent line blocked Solenoid energized : open to tank)  
 12 - Without manual override (Solenoid de-energized : vent line blocked Solenoid energized : open to tank)

**Pilot Connection**

2 - Internal PD - Internal PP<sup>2)</sup> (VR5V)  
 4 - External PD - External PP<sup>2)</sup> (VR5U)  
 5 - Internal PD - External PP<sup>2)</sup> (VR5U)  
 6 - External PD - Internal PP (VR5V,VR5S)



<sup>2)</sup> External pilot pressure connection on flange face

## PERFORMANCE

PC

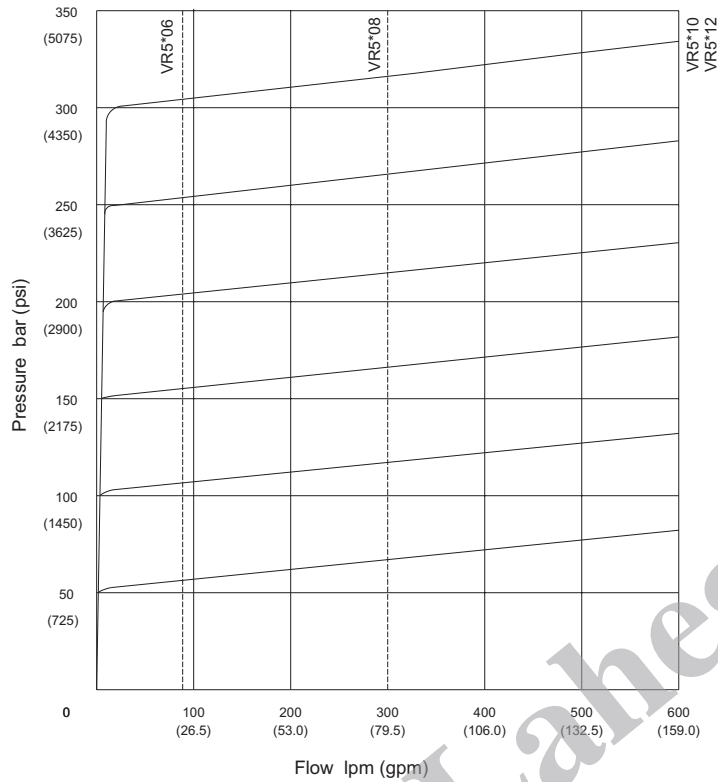

### P- Q Curves

Min. possible pressure setting > 3 bar. (43.5 psi)  
 Fluid 40 cSt at 50°C ± 0.5°C. (240 SSU at 120°F ± 32.9°F)

### Pressure Differential Characteristics for VR5U Unloader Valve

The differential between Unloading and Onloading is typical 15%. When system pressure (for instance accumulator) drops 15% below the pilot setting, the valve closes and pump feeds the system again.

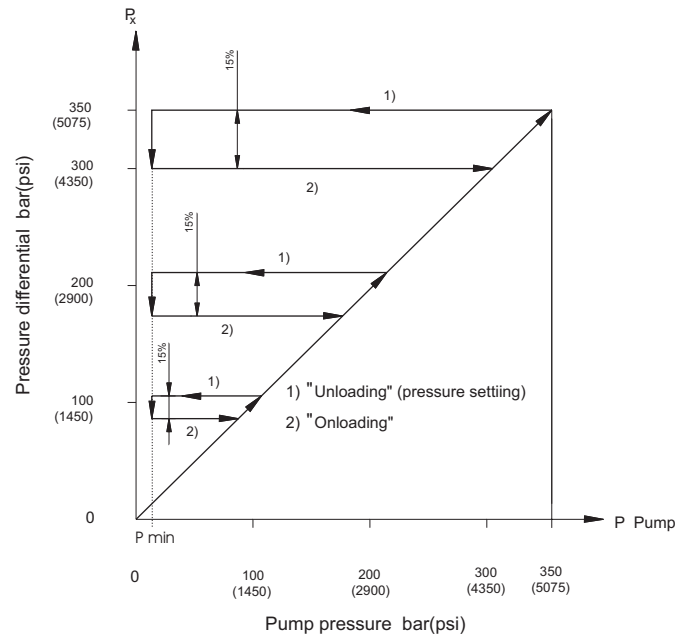

**VR5V10-VR5U10-VR5S10 ( 1 1/4" )**

Weight : 11.4 lbs (5.2 kg)

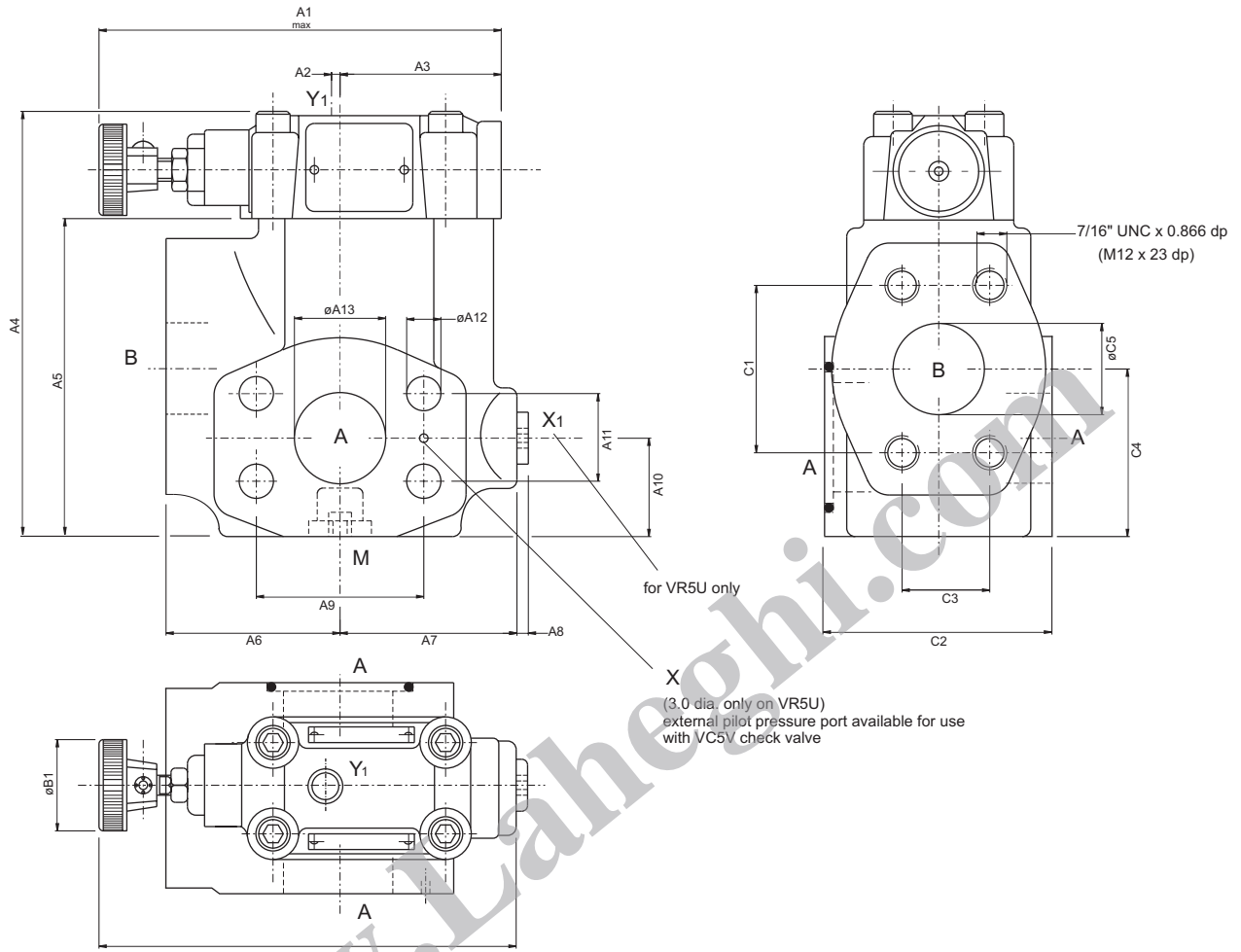

Dimensions	in mm	
	in	mm
A1	5.55	141.0
A2	0.12	3.0
A3	2.224	56.5
A4	5.87	149.1
A5	4.39	111.5
A6	2.402	61.0
A7	2.441	62.0
A8	0.16	4.0
A9	2.311	58.7
A10	1.35	34.5
A11	1.19	30.2
A12	ø0.472	ø12.0
A13	ø1.26	ø32.0

Dimensions	in mm	
	in	mm
B1	ø1.26	32.0
B2	5.77	146.6

Dimensions	in mm	
	in	mm
C1	2.31	58.4
C2	2.953	75.0
C3	1.19	30.2
C4	2.51	64.0
C5	ø1.26	ø32.0

Ports	Function	Port sizes	VR5V	VR5U	VR5S
A ( 2x )	Pressure	1" ( SAE - 61 )	●	●	●
B	Tank <sup>2)</sup>	1" ( SAE - 61 )	●	●	●
X <sub>1</sub>	Ext.Pilot port <sup>1)</sup>	1/4" NPTF or G 1/4" or SAE - 4		●	
Y <sub>1</sub>	Ext.Drain	1/4" NPTF or G 1/4" or SAE - 4	●	●	●
M	Pressure gauge	1/4" NPTF or G 1/4" or SAE - 4	●	●	●

1) Closed when supplied  
2) secondary port on VR5S

Note : VR5\*10 pressure controls mounted directly on 1 1/4" - SAE 61 Ports of VELJAN Vane Pumps ( "D" Cartridge)

**OPTIONAL CONTROL**

**Type of control - Code 3**  
Acron nut with lead seal

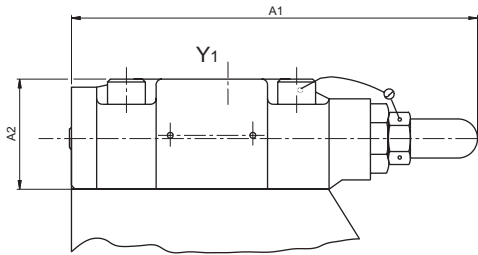

**Type of control - Code 2**  
Hand knob 50mm dia  
(not for version with vent valve VVV01)

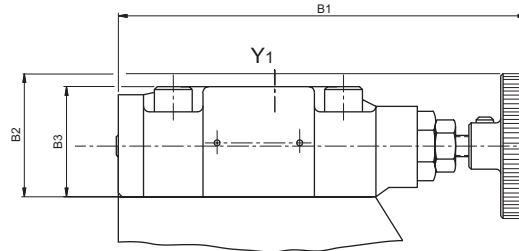

Dimensions		
	in	mm
A1	5.51	140.0
A2	0.49	38.0

Dimensions		
	in	mm
B1	5.55	141.0
B2	1.67	42.5
B3	1.49	38.0

Version with Vent Valve VVV01

Weight (VVV01) : 3.73 lbs (1.7 kg)

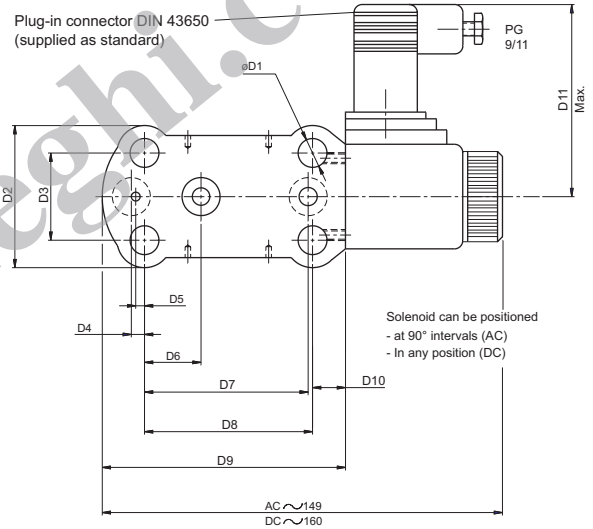
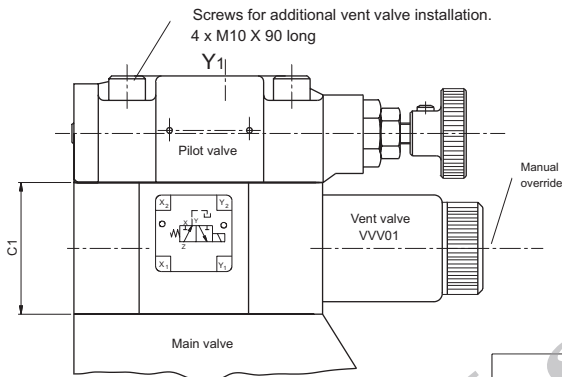

Dimensions		
	in	mm
C1	1.85	47.0

Dimensions		
	in	mm
D1	ø0.41	ø10.5
D2	2.03	51.8
D3	1.25	31.8
D4	0.18	4.8
D5	0.12	3.2
D6	0.81	20.6
D7	2.31	58.7
D8	2.37	60.3
D9	3.49	88.7
D10	0.51	13.0
D11	2.75	70.0

Code	Pressure Relief Valve VR5V		Pressure Unloading Valve VR5U		Sequence Valve VR5S
	Internal Drain	External Drain	Internal Drain	External Drain	External Drain
11 or 12					
09 or 10					

## SAE - Flanges

Inlet flange (only for pipe mounting)

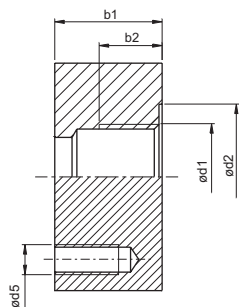
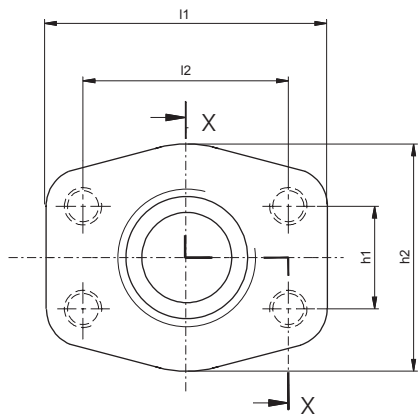

B.S.P.P Flange

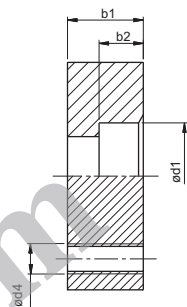

Socket weld

Outlet and tank port flange

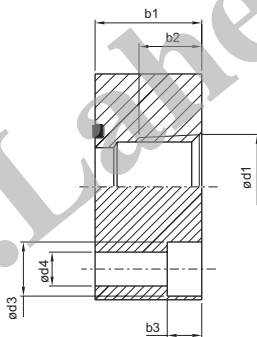
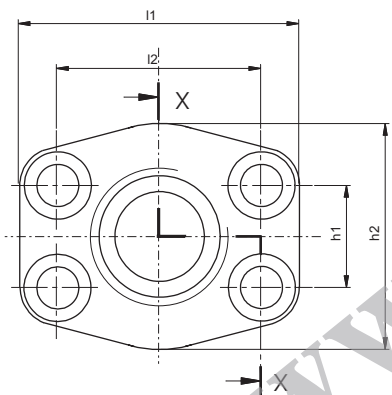

N.P.T.F flange

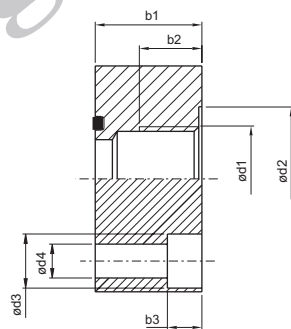

B.S.P.P flange

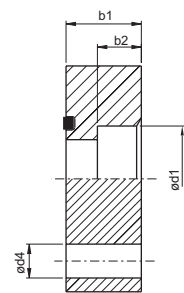

Socket weld

Port sizes d1	Inlet flange (without screws) only for pipe mounting	Outlet flange (without screws)	Tank port flange (with screws)											
	Order no.	Order no.	Order no.	l1	l2	b1	b2	b3	h1	h2	ød2	ød1	ød4	ød5
3/4" B.S.P.P	VS16-86520	VS16-86529	VS14-66933	67.0	47.6	34.0	15.9	12.0	22.0	52.0	40.0	16.5	10.5	3/8" UNC
3/4" N.P.T.F.	-	VS16-86530	VS14-66925			19.0	12.0	-			-			
3/4" Socket weld	VS16-86519	VS16-86528	VS14-66941			34.0	20.0	-			46.0			
1" B.S.P.P	VS16-86523	VS16-86532	VS14-66934	72.0	52.4	34.0	19.0	12.0	26.2	58.0	46.0	16.5	10.5	3/8" UNC
1" N.P.T.F.	-	VS16-86533	VS14-66926			24.0	14.0	-			-			
1" Socket weld	VS16-86522	VS16-86531	VS14-66942			39.0	22.0	15.0			54.0			
1 1/4" B.S.P.P	VS16-86526	VS16-86535	VS14-66935	80.0	58.7	39.0	20.6	15.0	30.2	73.0	54.0	17.5	12.5	7/16" UNC
1 1/4" N.P.T.F.	-	VS16-86536	VS14-66927			24.0	14.0	-			-			
1 1/4" Socket weld	VS16-86525	VS16-86534	VS14-66943			39.0	24.0	15.0			60.0			
1 1/2" B.S.P.P	VS26-52364	VS26-52215	VS14-66936	94.0	69.8	39.0	24.0	15.0	35.7	82.0	60.0	20.0	14.5	1/2" UNC
1 1/2" Socket weld	VS26-52366	VS26-52217	VS14-66944			26.0	16.0	-			-			
1 1/2" B.S.P.P <sup>1)</sup>	V464-01147	V464-01141	V464-01004			50.0	28.0	20.0			60.0	25.0		
1 1/2" Socket weld <sup>1)</sup>	V464-01149	V464-01143	V464-01146	112.0	79.4	50.0	28.0	20.0	36.5	94.0	-	-	17.5	5/8" UNC

<sup>1)</sup> SAE 62